



*Last Chance  
Stampede  
Queen*

*Contest Rules*



The Last Chance Stampede Queen Contest is to be held annually to select a young lady who has the **desire and enthusiasm to serve as a goodwill ambassador for the Last Chance Stampede and the sport of rodeo.** Miss Last Chance Stampede's primary duty is to promote The Last Chance Stampede throughout the year by traveling throughout the state representing the Last Chance Stampede Rodeo and Fair and its supporters. The Last Chance Stampede Rodeo Committee, and the Miss Last Chance Stampede Contest Coordinators are responsible for the ceremonies and activities necessary to select a titleholder. The Coordinators give direction, support and assistance to Miss Last Chance Stampede during her reign.

Contestants agree to abide by all the rules, regulations, agreements and contracts set forth by the Last Chance Stampede Contest. Breaking any eligibility rules, regulations, agreements or contracts will disqualify a contestant from the competition and cause forfeit of any titles. Miss Last Chance Stampede is responsible for carrying the title proudly, with integrity and fulfilling duties assigned by the Last Chance Stampede and Fair to the best of her ability.

#### **ELIGIBILITY**

1. Contestants must not be less than 18 years of age nor more than 24 years of age as of the first day of the competition. Birth Certificate is required.
2. Contestant must have obtained a high school diploma or equivalent of high school education.
3. Contestant must never have been charged with and/or determined to have committed any crime of moral turpitude, convicted of any offense, (other than minor traffic offenses) nor have had a title removed for any reason.
4. Contestants must grant permission to the Miss Last Chance Stampede Queen Contest to verify any and all information contained on the official Contest application and supporting documents.
5. Contestants must reside within the state of Montana and live within an 80 mile radius of Helena as of January 1 of the year of competition. Reasoning behind setting a radius is that the PRCA rule for LOCAL competitors is set at 50 miles. In order for us to expand the radius so that we could draw some of the main Metro areas which have PRCA rodeos, we settled on 80 miles which would include Great Falls and Bozeman. This will allow our queen to travel to some of the PRCA rodeos within this area. (Map shown on next page) Miss Last Chance Stampede must remain living within this area during her reign.

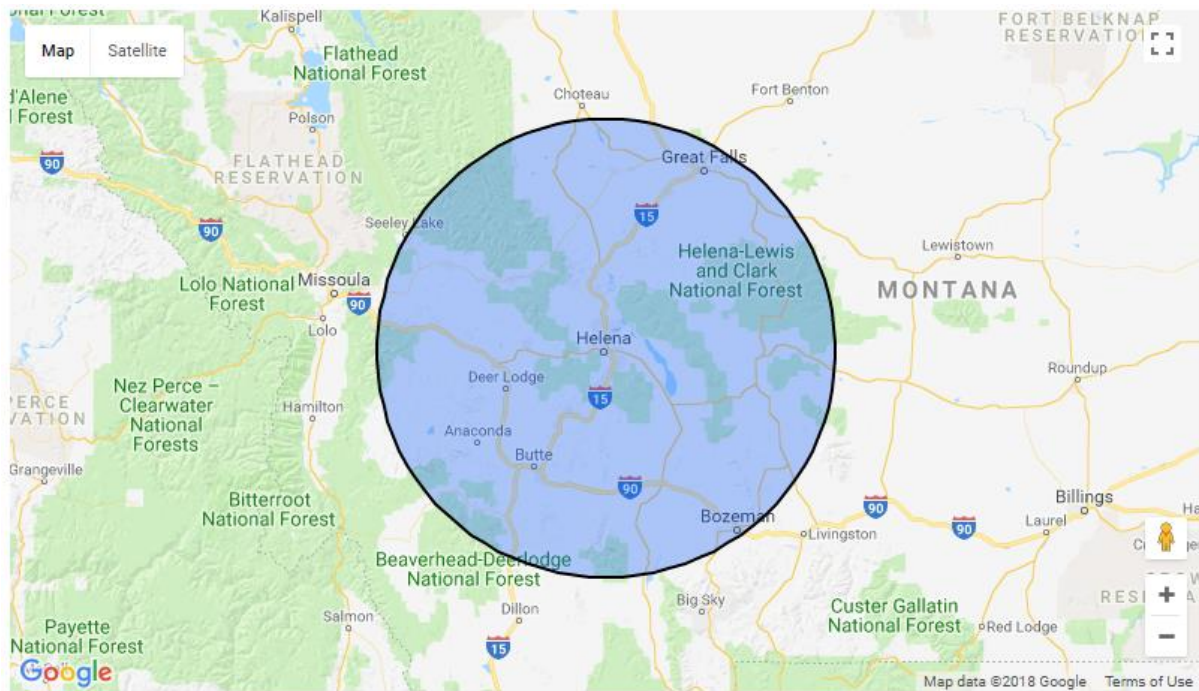

6. Contestants must not have held a State title or any other National title (with the exception of a High School, Junior or Teen) prior to competition.
7. Contestants must be single and never have been married. Contestants cannot be cohabitating with a member of the opposite sex.
8. Contestants must not be pregnant, or become pregnant during the coming year, and may not be the mother of a child out of wedlock.
9. All eligibility violations shall be discussed between the Rodeo Committee, the Fairgrounds Manager and the Queen Committee. The titleholder who violates any of the eligibility rules during her reign will relinquish all rights, prizes and privileges of her title at the request of the Queen Committee.

## GENERAL RULES AND REGULATIONS

1. Contestants must conduct themselves in a proper ladylike manner and portray high moral standards at all times. Contestants/Queen are not permitted to drink alcoholic beverages, smoke, or use inappropriate language or profanity at any time during the Contest, during the Last Chance Stampede or when representing Last Chance Stampede in the community.
2. Each contestant will submit one 8"x10" full length color photo one 8"x10" headshot color photo. These do not have to be professionally done, as professional photos will be taken during the contest. Photos must be in western attire. Western attire will include: western blouse, suit or dress, hat and accessories. Photos cannot be used from promotional photos of a previous contest.
3. Each contestant is required to submit a **NON-REFUNDABLE \$350 sponsorship fee (to be obtained by the contestant from sponsor of her choice)** from an approved list with her application. This should be payable to the Last Chance Stampede and Fair.
4. All applicants must complete the application process by returning the application form, the agreement/waiver, and the contract (6 pages in total) to the Last Chance Stampede Office **before 5:00 pm on June 1, 2019**.
5. A Contest judge may not be approached by a contestant or related individual with the intent to influence or harass. Action of this type can result in disqualification of the contestant at the discretion of the Committee.
6. The Contestant must be prepared to provide the appropriate horse and tack necessary for the horsemanship competition, and/or Last Chance Stampede parade, performances, and/or any activities throughout the year promoting Last Chance Stampede.
7. Contestants may not leave the Last Chance Stampede Queen Contest until the awards are presented (after crowning ceremonies). The Contest is not officially complete until contestants are checked out with the Contest Coordinators. They must abide by all Contest rules until they check out. Contestants not following these guidelines will jeopardize future eligibility, any runner-up status and/or awards.
8. Contestants must understand that, in the event of winning the contest, Miss Last Chance Stampede will work closely with Miss Last Chance Stampede Coordinators for fundraising and that fundraising is a necessary part of the title. A coronation event must take place not more than 3 months after the contest.
9. Contestants will provide their own transportation to and from Contest activities unless otherwise noted on the schedule of events. Contestants will provide their own lodging during the contest.
10. Miss Last Chance Stampede must not solicit, negotiate, or contract with any third party for appearance photographs, interviews, sponsorships, and/or endorsements in relation to the Title of Miss Last Chance Stampede during the year of her reign without the express permission of the Last Chance Stampede Committee and Fairgrounds management.
11. Titleholder must not take any actions which will or is reasonably likely to cause harm or damage to the goodwill or reputation of Miss Last Chance Stampede Title, L & C County, Last Chance Stampede and Fair or the Lewis and Clark County Fairgrounds.
12. Titleholder will not violate any provision of the participation agreement, Miss Last Chance Stampede agreement, or Contest rules and regulations.
13. **NOTE: First Runner up will be prepared to take over the reign of Miss Last Chance Stampede, should she not be able to complete her reign, i.e. winning a title of Miss Rodeo Montana, etc. and will be required to sign a contract.**
14. Contestants must provide their own wardrobe and agree to follow the wardrobe guidelines. Each contestant should have at least one complete western elegance outfit, one complete horsemanship (arena dress) outfit (as outlined in the requirements), and one complete casual dress outfit. Please

see wardrobe guidelines section in the rules for more information. **It is up to the contestant as to how many outfits she brings to the Contest.**

Contestant's application packet is due in the **Fairgrounds Office on or before June 1st, 2018** and must include:

- ♦ Official Application
- ♦ Signed Initialized and notarized application agreement
- ♦ Photos
- ♦ Photocopy of birth certificate
- ♦ Photocopy of Montana Driver's license
- ♦ Sponsorship fee (it is the contestants responsibility to obtain this sponsorship)
- ♦ Application pictures must be as follows: One 8 x 10 full length and one 8 x 10 head shot. These do not need to be professionally done. **IMPORTANT:** If there are copyright labels or stamps on the back of your pictures, you need written permission from your photographer for Miss Last Chance Stampede to use your photos for publicity. This should be included in the application packet. You must wear western attire including a cowboy hat for the photos.

**SPORTSMANSHIP:** The Last Chance Stampede Queen Contest Committee expects each contestant to display the highest degree of sportsmanship and integrity during the Contest, at the parade, during and following coronation and during the Last Chance Stampede. Each contestant should be mindful that they are representing the Last Chance Stampede Contest, the sport of rodeo, the Last Chance Stampede and Fair, as well as Lewis and Clark County. **Unsportsmanlike conduct could result in disqualification and affect future eligibility to compete in the Last Chance Stampede Contest.**

**Contestants will be required to be on a radio talk show at least one time prior to the contest. This may be judged.**

## CONTEST DIVISION RULES

Awards will be given to the girl scoring the highest during all Contest activities in the following categories: Horsemanship, Appearance, Personality, Speech, and Photogenic. The overall winner will be crowned Miss Last Chance Stampede with the next highest individuals receiving First Runner-up. Other awards include, but are not limited to: Miss Congeniality, Speech and Horsemanship.

**HORSEMANSHIP-** The purpose of this category is to select the young lady who rates the highest in:

- ♦ **Horsemanship-** including control of mount, proper ring etiquette and the way each situation that might occur is handled.
- ♦ **Equitation-** balance and effectiveness-ability and position of hands, feet and seat when riding at a reasonable rate of speed for the activity.
- ♦ **Pattern-** understanding of leads and proper execution of a specific pattern.
- ♦ **Mounting and dismounting.**
- ♦ **Queen presentation ride and flag run.**
- ♦ **Knowledge** of horsemanship and horse science. The following categories may be used in impromptu questions and interviews: tack, horse science (including feeding, grooming, parts of the horse, health care, etc.), professional rodeo and history of rodeo, rodeo terminology, and explanation of rodeo events, championship rodeo standings and current issues of the pro rodeo circuit and/or the PRCA, current events and/or comparison questions.
- ♦ **Showmanship-** including how well a contestant projects her personality to the audience from horseback.
- ♦ **Attire-** required attire for horsemanship is in the **Wardrobe Guideline** section of the rules.

**Other considerations in Horsemanship include, but are not limited to the following:**

- ♦ Understanding and skill of *the contestant* will be judged, NOT the horse or equipment.
- ♦ Each contestant will be required to provide her own horse, which can be ridden in a bridle with one hand on the reins.
- ♦ Five horsemanship patterns will be provided to the contestants in their information packet and two of these patterns will be used in the competition. The patterns are selected by the judges and announced just prior to the horsemanship competition.
- ♦ There will be two go-rounds in this competition with the draw order announced at the Judges Reception.
- ♦ NO CHAPS will be allowed in the competition.
- ♦ Judges may talk to the contestants, or ask horsemanship questions in the arena, during the Horsemanship Lunch and/or during Horsemanship Interviews.
- ♦ All contestants will be asked to do rail work at a walk, trot and lope, make a presentation run at reasonable speed, ride a specific pattern, and carry a flag during a flag run. Flag boots will be provided.

For your safety, please make sure the horse you bring is familiar with being in a rodeo setting and carrying a flag.

- ♦ Other arena work will be at the discretion of the judges and Contest Committee.
- ♦ Tack need not be expensive or flashy, but must be clean, safe and properly cared for.

**APPEARANCE-** The purpose of this category is to select the young lady who rates highest in:

- ♦ **Attractiveness**
- ♦ **Grooming:** including meticulous care in neatness and cleanliness *in every detail* such as complexion, hands, fingernails, hair, hat, boots, and other wearing apparel.
- ♦ **Posture:** including carrying themselves straight and tall with self-confidence and poise.
- ♦ **Poise and ladylike behavior** in every situation: This should include handling each situation with grace, style and proper etiquette.
- ♦ **Western Fashion Sense:** including western outfits that are fashionable, tasteful and properly fit to the contestant and the Contest event. Attention will be given to a contestant's ability to use color and style to enhance her personal features. Additional information is in the **Wardrobe Guidelines** within these rules.
- ♦ **Proper fit of Clothing:** including figure flattering styles altered for a personal fit, and properly fitted and shaped hats. Judges will be looking for versatility and imagination and a contestant's ability to carry out a "total look" rather than an excessive amount of clothing.
- ♦ **Knowledge** of the Western Clothing industry: including knowledge of the major western wear manufacturers, the latest trends in the western wear industry, and the companies that sponsor PRCA rodeos and rodeo attire rules.

**Other Considerations in Appearance include, but are not limited to the following:**

- Contestants will be asked to model outfits for the modeling portion of the contest as well as their Western Elegance outfit.

**PERSONALITY-** The purpose of this category is to select the young lady who rates the highest in:

- ♦ **Conversational Ability** in varied areas with an emphasis on grammar, enunciation and speaking etiquette.
- ♦ **Intelligence and common sense**
- ♦ **Sense of Humor**
- ♦ **Self-Confidence, high moral standards, sincerity and integrity**
- ♦ **Genuine interest** in other people and consideration of others.
- ♦ **Self-Projection** or the ability to project one's personality in a natural way whether on horseback, on stage or in personal interactions.
- ♦ **Positive** outlook on life.
- ♦ **Promptness and cooperation.** Please note that if a contestant fails to arrive on time for *any* Contest event, she may be disqualified at the Committee's discretion. Tardiness is not a desirable attribute.
- ♦ **Maturity**
- ♦ **Academic** background and career goals.

**SPEECH-** The purpose of this category is to select the young lady who rates the highest in:

- **The ability to communicate** with an audience using appropriate and correct sentence structure, vocabulary, grammar and projection.
- **The ability to prepare** for a speech.
- **Self-Projection** on stage: including delivery, voice, manner and use of a microphone.
- **The ability to present** a speech of three to four minutes in which the content is well developed, interesting, understandable and which most fits the speech topic. **(See Below)**



**Other considerations in Speech include but are not limited to:**

- ♦ Speeches must be between three and four minutes in length. Deductions will be made for speeches shorter than three minutes or longer than four minutes.
- ♦ Speeches should be memorized. No props or visual aids will be allowed.
- ♦ Contestants will also be asked to present a short biographical sketch of themselves in the form of a short speech (30-60 seconds) and to introduce themselves at various activities.
- ♦ Impromptu questions will be judged separately from the speech.

**SPEECH TOPIC 2018**

**“LAST CHANCE STAMPEDE: A Little of the Old, With A Little of the New”**

**PHOTOGENIC:** The purpose of this category is to select the young lady who rates highest in: **Ability to photograph-** including strength of character, personality and wholesomeness.

**OVERALL IMPRESSION:** This category is the judges overall impression of the contestant throughout the Contest.

**CONGENIALITY:** This category is chosen by the contestants and will not affect the judges' scoring of previously listed categories or the selection of Miss Last Chance Stampede. The title of Miss Congeniality should go to the contestant that is most friendly, helpful and supportive of all the other girls.





## WARDROBE GUIDELINES

**PLEASE NOTE:** Appearance is very important but it is not necessary to invest in an excessive amount of expensive clothing, nor to have a different outfit for each event. You are not judged on the number of outfits you have nor if they are hand made or designer label, leather or cotton. The outfit should fit whichever element of the contest you are in at the time. What is important is for you to be clean, neat, and presentable. You may choose to wear the same outfit or a combination of two different outfits to several portions of the contest. Be Creative!

### ARENA DRESS

Each contestant should have one complete horsemanship outfit. Horsemanship attire can consist of Flashy western long-sleeved blouse, must be tucked in. Wrangler jeans, any style any color (including blue jeans in good condition) may be worn. Boots, belt, hat and accessories. Color and style has been left up to the discretion of the contestant. The horsemanship outfit will be worn for individual horsemanship interviews as well. No jackets or vests permitted in the horsemanship competition, but vests/and or jackets allowed in every other event requiring arena dress.

### CASUAL Western

Pants and shirt. Casual outfits should not be overly flashy or gaudy. Vests and jackets are permitted. Shirts must be long-sleeved and tucked in.

### WESTERN ELEGANCE

Each contestant should have at least one complete western dress or skirt outfit with accessories. Minimum length should cover top 1/3 of boot top. Split skirts in good taste are permitted. Be creative. Sequins, appliques, accent sequins or stones may be used, but will not add to judges overall score of the outfit.

### WITH ALL ABOVE OUTFITS

Western hat and boots required with all outfits

No straw hats

No fashion heels.

Long Sleeves on all outfits

No Cleavage: nothing bra-less

Proper slips under skirts and dresses

Split skirts must be in good taste

No lace-up boots permitted

Belt and buckle

Contestant banner (provided)

Remember to bring hat covers in case of rain. Dress for the weather.

NO chaps or spurs, crowns or banners from previous Contests are to be worn by contestants during the Miss Last Chance Stampede Contest. The exception would be a contestant/sponsor banner that may be provided by the Contest committee and required for some activities.

Contestants are required to write a description (one minute in length) of their Western Elegance outfit they will be wearing for the modeling segments. **This must be typed on a 3x5 card with a minimum 12 pt. font and turned in to the Contest director at the Judges Reception. Failure to comply may be cause for disqualification.**

## GENERAL INFORMATION

**PARENTS, FRIENDS, AND RELATIVES** - The Last Chance Stampede Queen Contest welcomes and encourages the presence of parents, friends, and relatives during the competition. The Contest Committee requests *complete cooperation* from these supporters during Contest activities. **At no time during the Contest shall parents, friends and/or relatives disturb contestants or approach the judges.** During the Contest activities, the contestants will be **required** to be together as a group without coaching or other distractions by parents, friends, and/or relatives.

**Some Contest activities are open only to Contestants, Committee and Judges. If parents, friends and/or relatives attend closed events, the contestant they support may be disqualified from the Contest at the Committee's discretion.**

Parents, friends and/or relatives are invited to attend all speech and modeling activities and are responsible for obtaining tickets for all events. An order form for tickets will be included in the contestant package as well as online at [www.lccfairgrounds.com](http://www.lccfairgrounds.com).

**PHOTOGRAPHS taken of contestants before or during the Contest will become property of the Last Chance Stampede Queen Contest.**

**CHAPERONES and SECURITY:** The Last Chance Stampede Queen Contest coordinators will act as chaperones during the contest activities. Upon commencement of the contest, the contestants are under the jurisdiction of the contest for all activities.

**PROBLEMS and COMPLAINTS:** Any problems and/or complaints should be *immediately* referred to the Last Chance Stampede Queen Contest Chairman. The Last Chance Stampede Chairman, the Fairgrounds Manager and Committee have full authority over the contest and any decision they make regarding rules and/or participation is final.

**STUDY INFORMATION:** The Last Chance Stampede website at [www.lccfairgrounds.com](http://www.lccfairgrounds.com) contains important information about the Last Chance Stampede. Other links and information will be listed on the site. The PRCA publishes a PRO RODEO MEDIA GUIDE and a bi-monthly newspaper, the PRO RODEO SPORTS NEWS. These are just a few of the resources that provide excellent information for study material. For more information contact the PRCA at 101 Pro Rodeo Drive, Colorado Springs, CO. 80919 (719) 593-8840, or visit their website at [www.prorodeo.com](http://www.prorodeo.com). Additional study materials and resource research are up to the contestant.

**Questions should be directed to Last Chance Stampede Queen Contest Committee Chairman:**



## JUDGING

The Last Chance Stampede Queen Contest Committee will use the following procedures for judging:

1. Qualified Judges selected for their Contest judging experience will judge all parts of the contest.
2. Decisions of the judges are final.
3. In the event of a category tie, the decision will be made by the judge(s) of that category. However, no points will be added to or subtracted from contestant's scores.
4. In the event of a tie for Miss Last Chance Stampede or a Runner-up, the decision will be made by the Contest judges. No points will be added to or subtracted from the total points earned.
5. Contestants will vote on the selection of Miss Congeniality and Contest judges will select the winner of the Horsemanship Award. There will be no extra points given for these awards. In the event of a tie for these awards, duplicate prizes will be awarded to winning contestants.
6. The services of an Accountant will be used to tally the judging sheets.
7. Contest officials will not have access to completed judging sheets. A head judge will be chosen. The head judge will put completed score sheets from all of the judges in a sealed envelope and sign the seal. The sealed envelope will be delivered to the accountant.
8. An individual's scores and judge's comments will be available to her not less than thirty days after the Contest via a written request to the Queen Committee Chairman from the contestant. The scores can be requested by regular mail on the provided request form. Requests made in any other manner will not be accepted.



# Judging Guidelines

(Each judge scores as follows - there will be 3 judges total for each phase of competition).

Category Awards	Per Judge	Total X 3 Judges
Horsemanship	285	855
Photogenic	20	60
Speech	70	210
Appearance	245	735
Personality	245	735
Other	120	360
<b>TOTAL</b>	<b>985</b>	<b>2955</b>

An unidentified judge/person will be observing the contestants during the contest and will score them a maximum of 50 on how well they interact with the public, judges and other contestants, answering questions, being respectful and overall how they would represent the rodeo if they were chosen to be the new queen.



(THIS MAY CHANGE)

## Miss Last Chance Stampede Contest

Tentative Schedule

### Wednesday, July 18, 2018

4:00 pm Judges Orientation and Photo Judging

### Thursday, July 19, 2018

2:00 – 4:00 pm	Contestant Welcome and Check ins	Western Fashion forward Attire
4:00 – 5:30 pm	Horsemanship test	
6:00 – 7:30 pm	Get Acquainted Dinner and Impromptu Questions (Ticket Required)	
8:00 – 10:00 pm	Fashion Show Rehearsal	Casual wear

### Friday, July 20, 2018

8:00 am	Style Show Fittings, Murdochs	Western Casual
9:30 am -11:30 am	Personal Interviews	Western Elegance or Western Business
12:00 – 4:30 pm	(Lunch) and Modeling, impromptu speech	Western Elegance

### Saturday, July 21, 2018

9:00 am - 12:00 noon	Horsemanship – Fairgrounds Arena (public invited)	Arena Dress, No jackets or vests
5:00 pm – 8:00pm	Banquet Dinner, Speech Competition (tickets available)	Western Elegance

### Thursday, July 26, 2018

10:00 am – 1:00 pm	Help with Kiddie Parade	Arena Dress
2:00 pm – 4:00 pm	On Grounds Meeting and Interacting with people, signing at Booth	Arena Dress
6:30 PM	Sell Programs at the Rodeo	

### Friday, July 27, 2018

2:00 pm – 4:00 pm	On Grounds Meeting and Interacting with people, signing at Booth	Arena Dress
4:00 – 5:30 pm	Production Meeting/VIP Room	Arena Dress
6:30 PM	Sell Programs at the Rodeo	

### Saturday, July 28, 2018

11:00 – 1:00	Stampede Parade	Arena Dress
2:00 pm – 4:00 pm	On Grounds Meeting and Interacting with people, signing at Booth	Arena Dress
6:45 – 7:00 pm	Crowning, Miss Last Chance Stampede Sell Programs at the Rodeo	

## Horsemanship Patterns

### Pattern #1

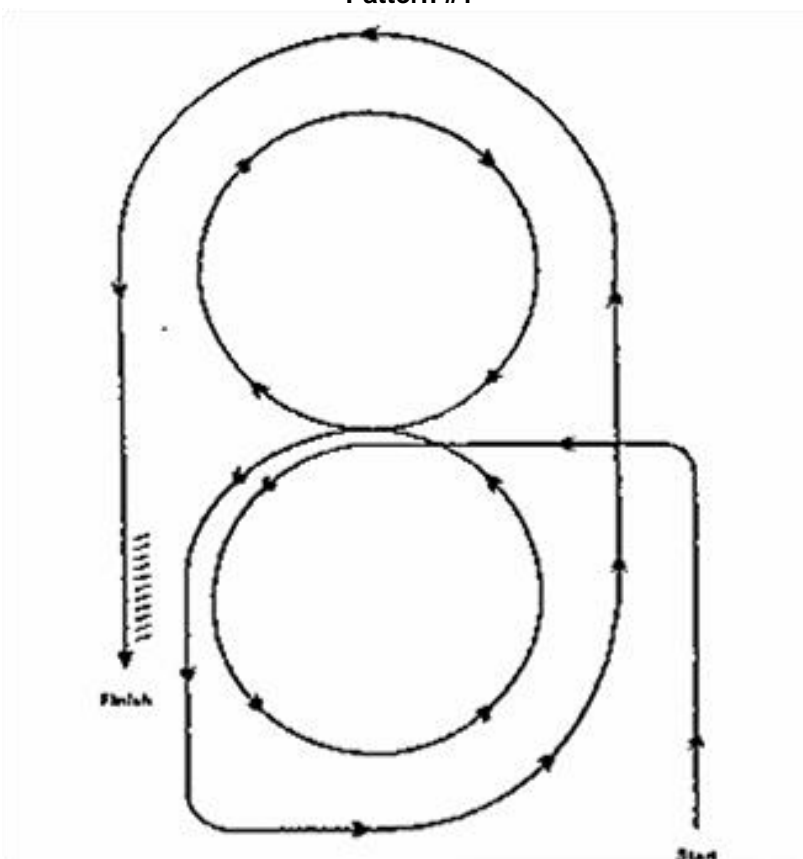

1. From Start, extended jog along side of arena, then to center.
2. Begin lope at center of arena, picking up left lead and lope left circle on left lead.
3. Change leads at center of arena and lope right circle on right lead.
4. At center of arena, change leads again to left and ride to end fence, making a sharp left turn.
5. Continue loping along end of arena, gradually turning so that you will be on the straight, heading to the other end.
6. Increase speed on the straight and continue around end of arena in half circle.
7. At  $\frac{3}{4}$  of the way down the pattern, stop and back your horse 3 steps.
8. Wait for judge nod to dismount.
9. Lead to judges for dismissal.



### Horsemanship Pattern Pattern #2

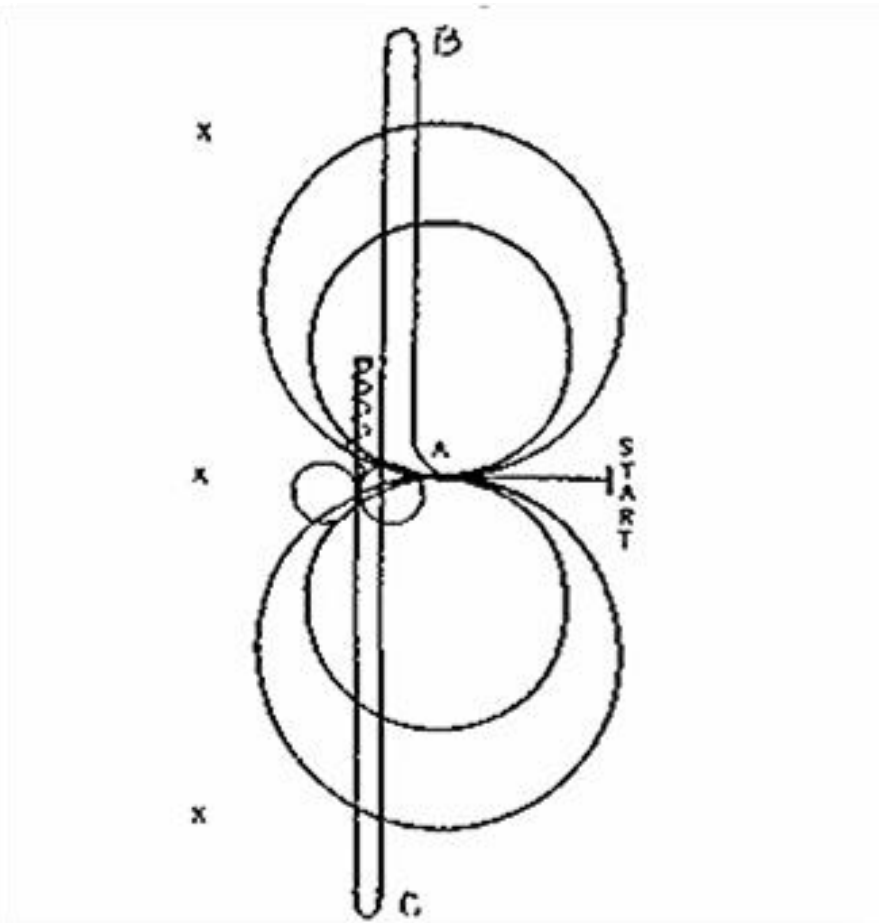

1. Beginning at start, lope one small slow circle and one large fast circle to the right.
2. Change leads at A.
3. Lope one small slow circle and one large fast circle to the left.
4. At A, begin building speed to B, stop and rollback on the left.
5. Lope, building speed to C, stop and rollback to the right.
6. Lope past center marker, stop and back 10-15 steps. Settle horse.
7. Spin once to the left, and once to the right. Settle horse.
8. Wait for judges nod to dismount.
9. Lead to judge for dismissal.





Horsemanship Pattern  
Pattern #3

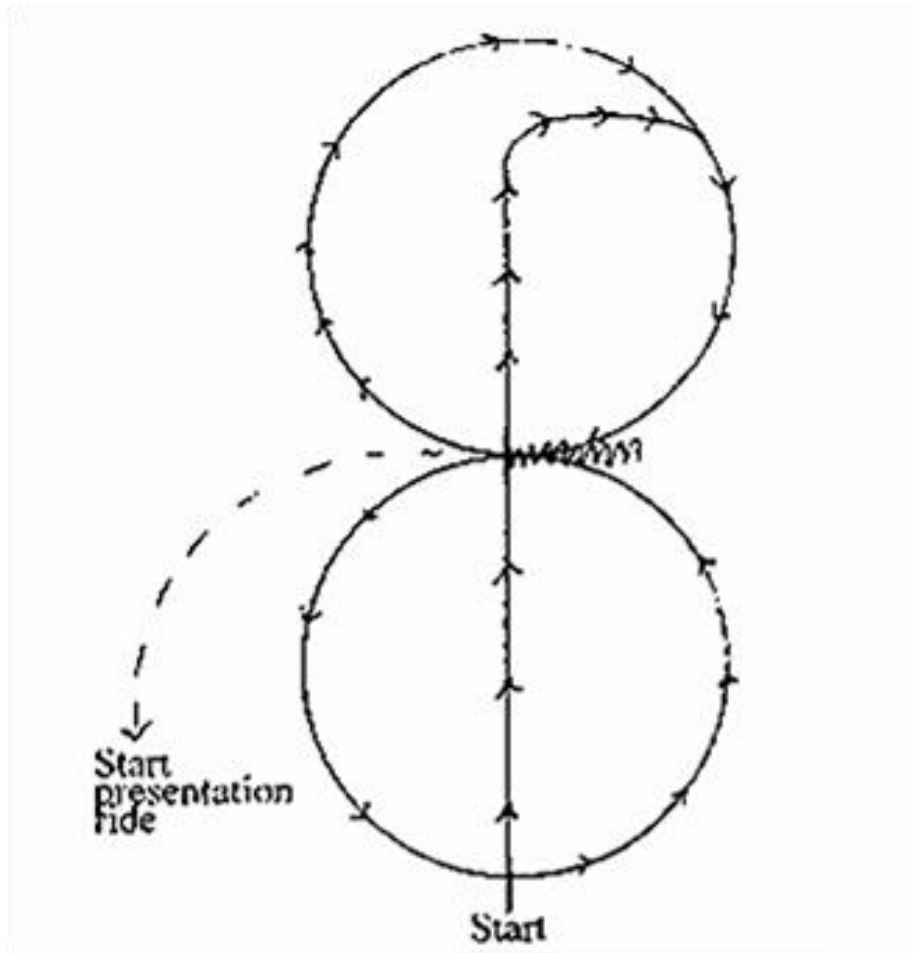

1. From Start, Walk to center of arena, then proceed at a jog nearly to the end of the arena. Without stopping, pick up right lead and circle to the right.
2. Change leads at the center of the arena and lope a circle to the left.
3. Change leads at the center of the arena and lope a circle to the right.
4. At the center of the arena, stop and back approximately 10 steps. Settle horse.
5. Start presentation ride to the left from the center of the arena.
6. Wait for Judge nod to Dismount and mount for judges at the end of the presentation ride.
7. Wait for judge to dismiss.



Horsemanship Pattern  
Pattern #4

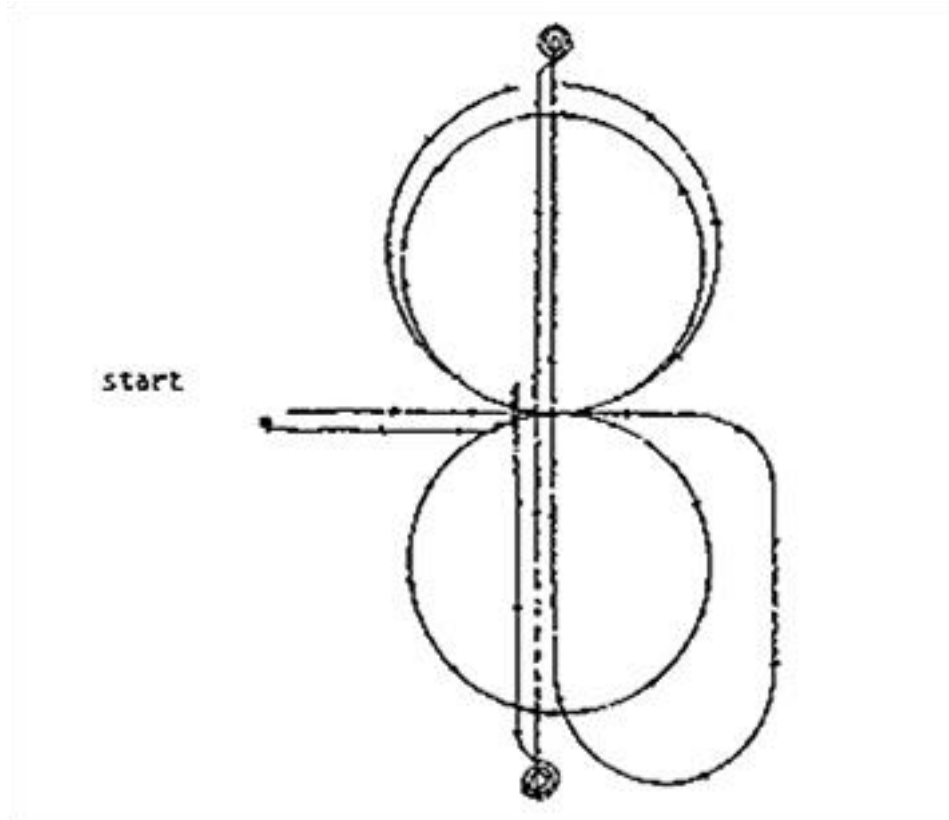

1. From Start, begin at center of arena. Lope a circle to the right at moderate speed.
2. At the center of the arena, change leads and make two circles to the left of approximately the same size and speed.
3. At the center of the arena, change leads and lope a wide circle to the right, beginning a straight run at the mid point of the circle.
4. Go the full length of the arena, stop and rollback to the right.
5. Begin a run to opposite end of the arena, stop and rollback to the left.
6. Run past the Center of the arena, stop and back horse appx. 10 steps.
7. Settle horse.
8. Wait for judge's nod to dismount.
9. Wait for judge's dismissal.



## Horsemanship Pattern Pattern #5

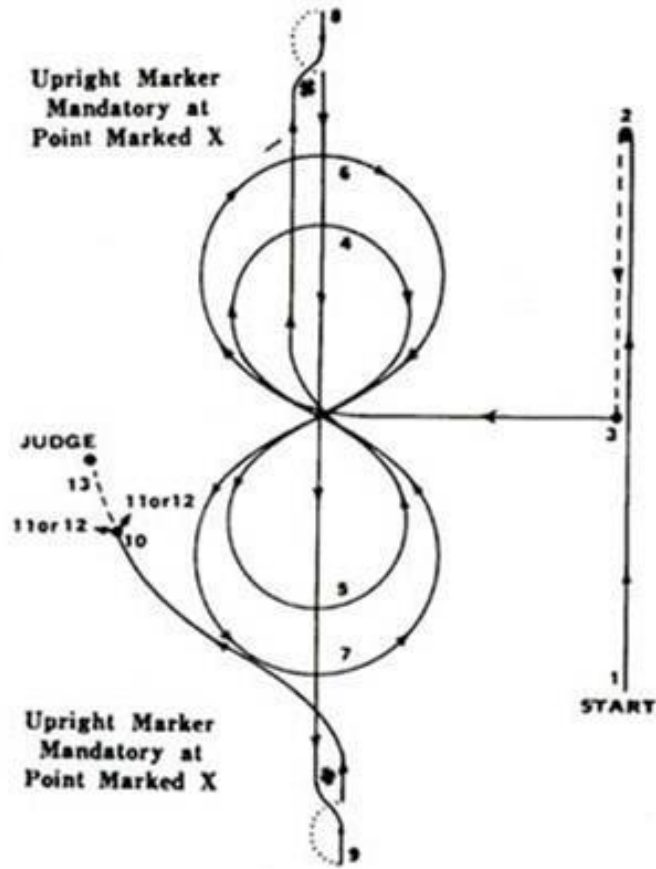

- 1 to 2. Run at full speed (should be at least 20 feet from fence or wall)
2. Stop and back
3. Settle horse for 10 seconds.
- 4 & 5. Ride a small figure eight at a slow lope
- 6 & 7. Ride large figure eight at a fast lope
8. Left roll back over hocks. Upright markers are mandatory at points marked X on the pattern.
9. Right roll back over hocks.
10. Stop
11. Pivot left or right.
12. Pivot opposite direction.
13. Pick up flag and present
14. Walk to judge and stop for inspection until dismissed.

